

**TerraTrike®**  
PART OF THE SOLUTION

THE **ROVER** TANDEM  
ATTACHMENT



**Assembly Guide  
Pilot's Handbook  
Technical Illustration  
&  
Parts List**

**www.TerraTrike.com - 800.945.9910  
4525 Stauffer Ave SE, Suite A.  
Kentwood, MI 49508 USA**

## Table of Contents

- Pg 1 - Installation Rover Tandem Attachment
- Pg 2 - Installation Stoker (Rear) Crankset
- Pg 3 - Captain (Front) Chain Installation
- Pg 6 - Rear Wheel and Stoker (Rear) Chain Installation
- Pg 7 - Chain Tube Installation, Handle Bar Installation, Shifter Cable extension Installation
- Pg 8 - Seat Installation, Important Riding Tips
- Pg 10 - 2011 X-seam Chart (for newer Rovers)
- Pg 11 - 2010 X-seam Chart (for first generation Rovers)
- Pg 12 - Owners Information
- Pg 14 - Warranty Information
- Pg 15 - Rover Tandem Owners Information
- Pg 16 - Seating Adjustment, Tire Pressure
- Pg 17 - Notes
- Pg 20 - Comapny Information

## Assembly Guide

Dark Grey = Installation/Adjustment

**IMPORTANT:** If you already have an assembled trike, some dis-assembly is required.  
Perform steps 6, 5, 4 from your "Rover Assembly Manual" to dis-assemble -  
<http://www.terratrike.com/manuals.php>

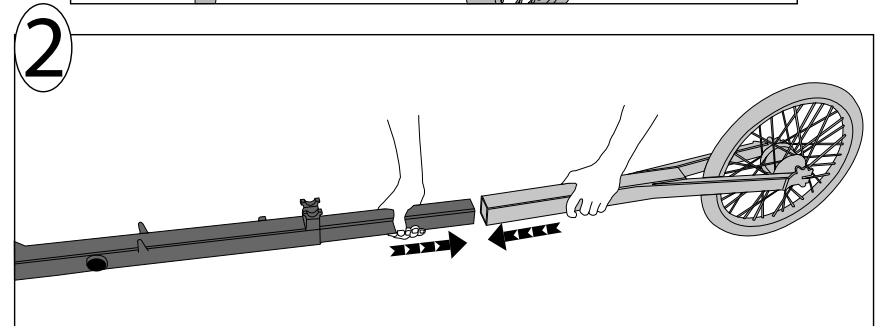
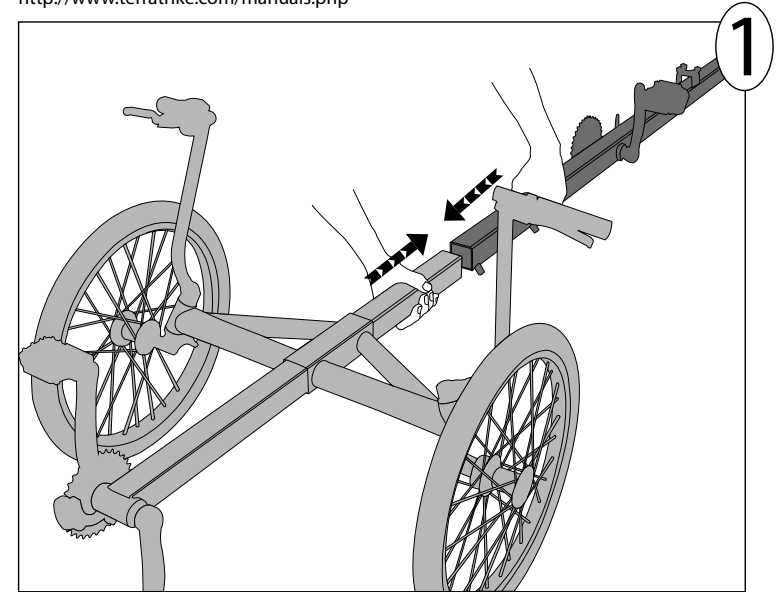

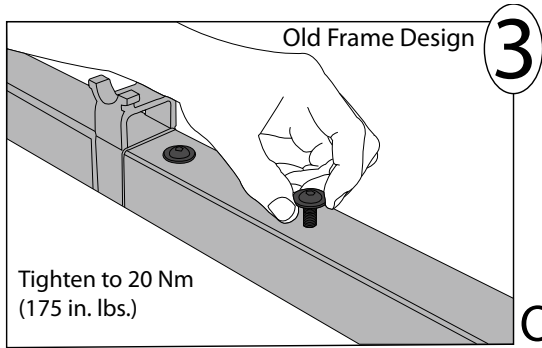

OR

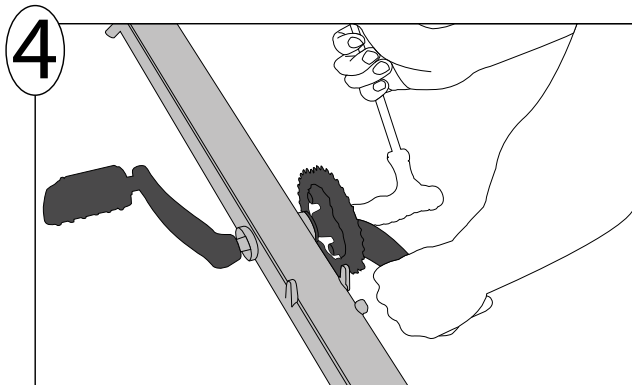
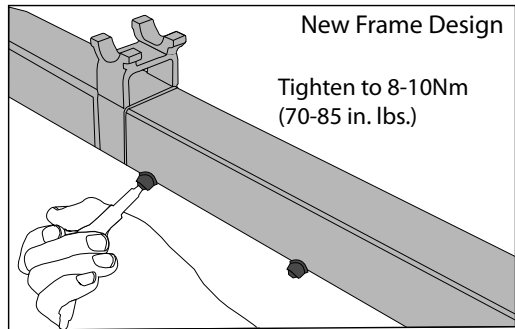

Install bottom bracket and crankset onto frame extension

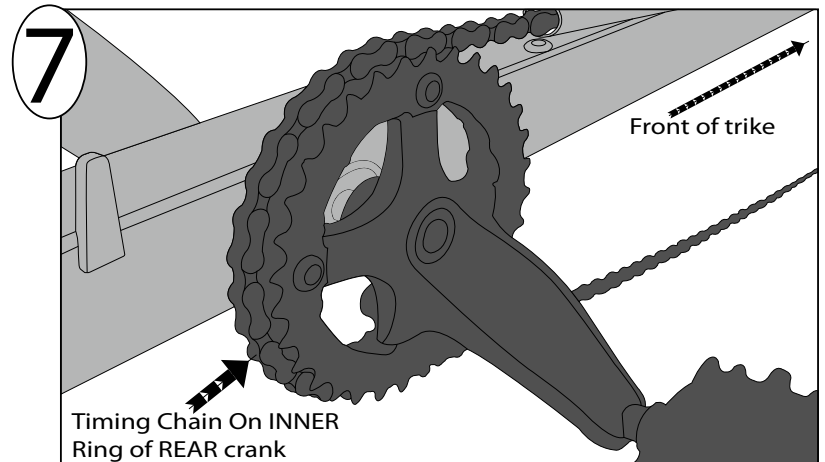
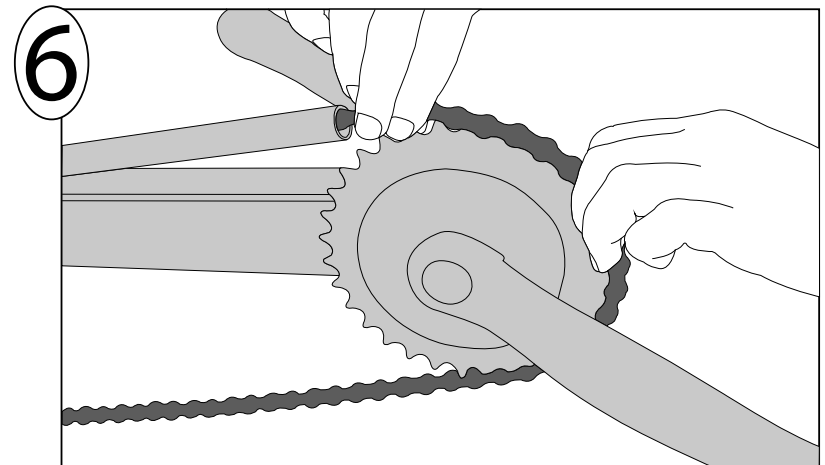
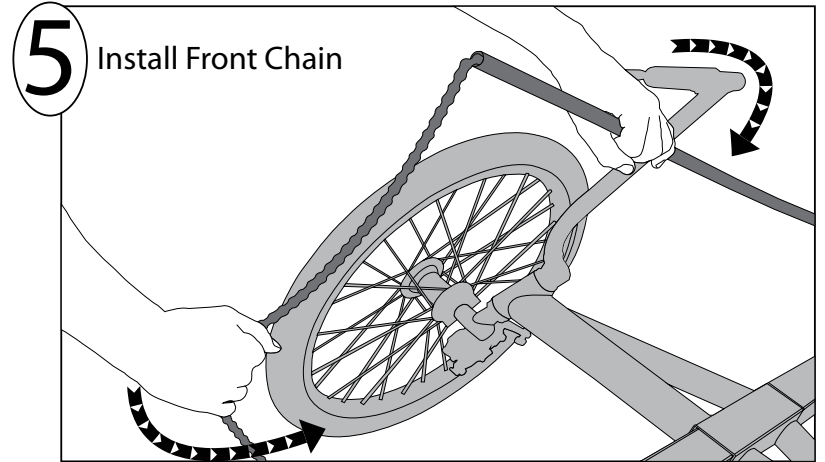

**DEALERS:** Tandem parts include front and rear chains sized for a medium captain (front) position. If you need a long captain size of chain, you will need to add the 5" section of chain. If you need a short captain size, you need to remove 5" of chain from the FRONT chain. THE 5" MEASUREMENT INCLUDES MASTERLINK.

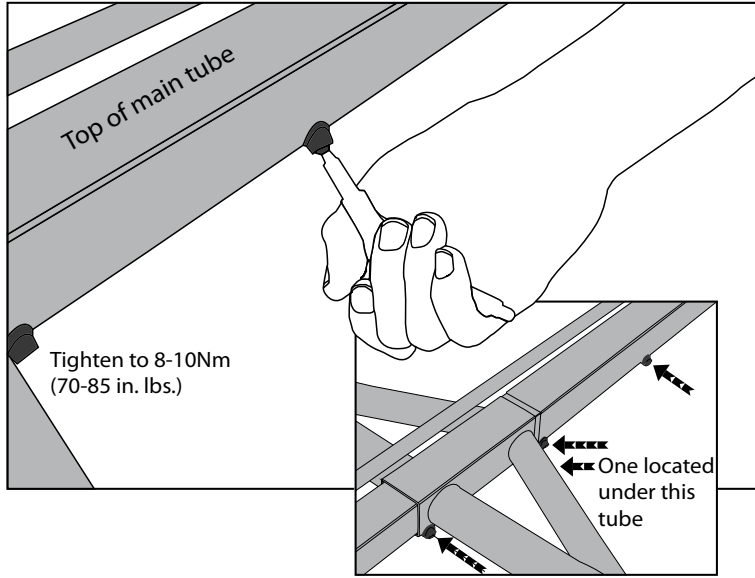
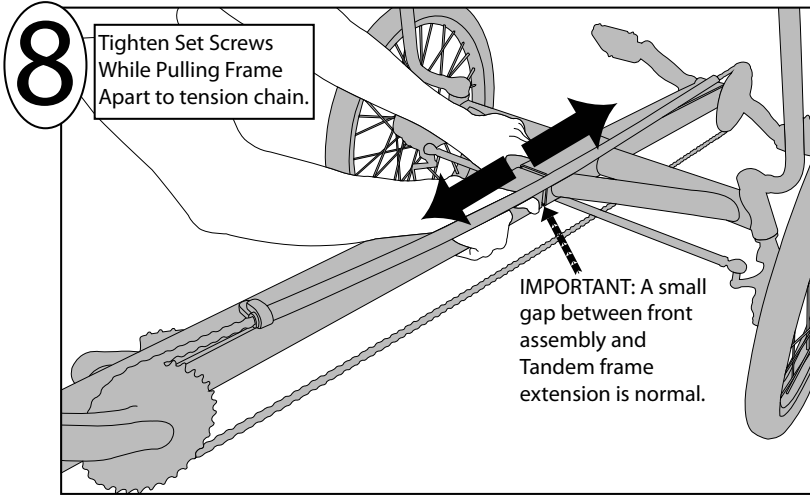

Chain Installation Cont.  
When Installing chain, make sure your cranksets are offset 90 degrees.  
This only applies to a NON-IPS (independent pedaling system) drivetrain.

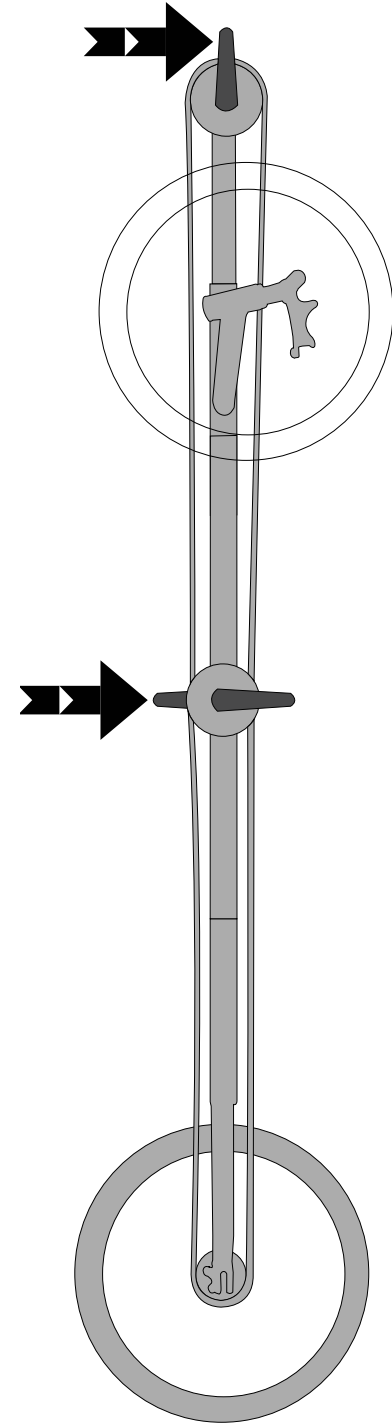

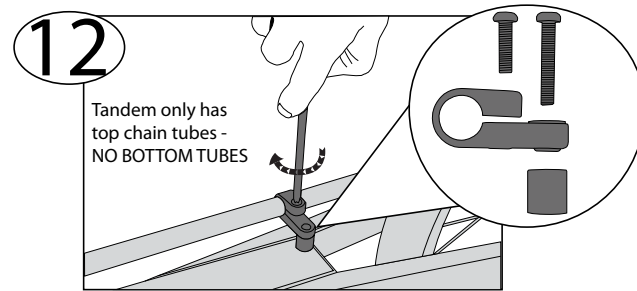
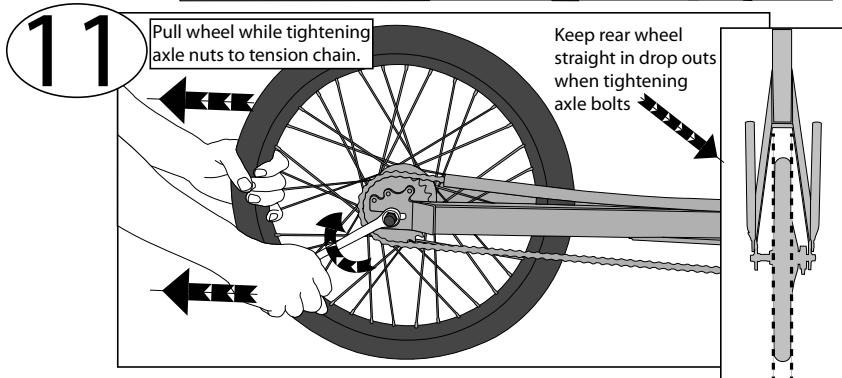
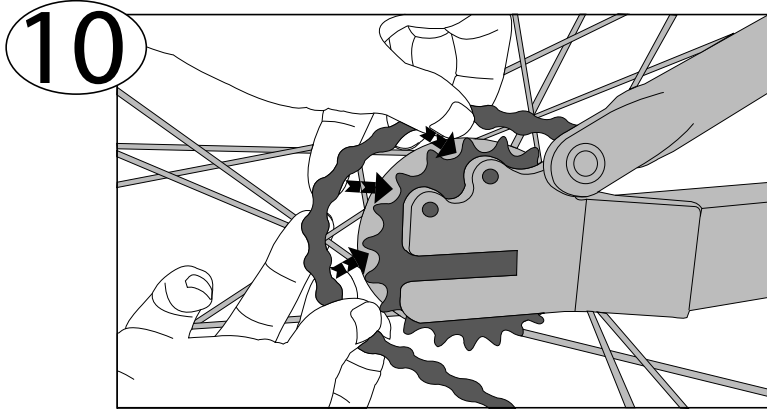
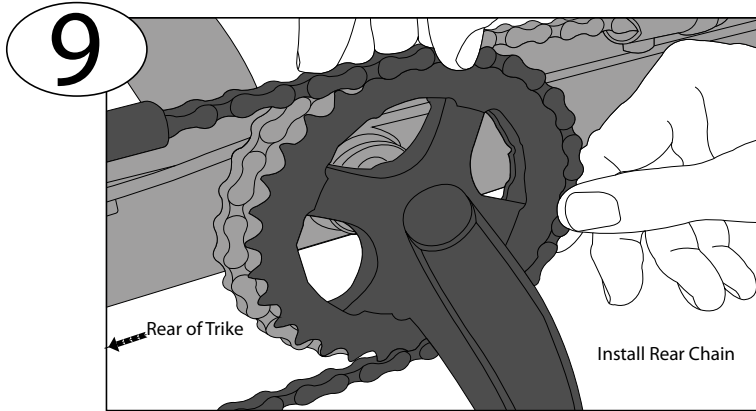

OR

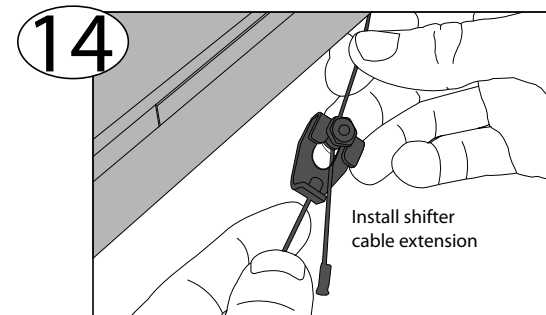
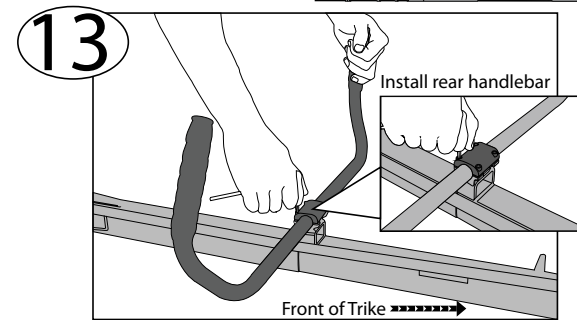
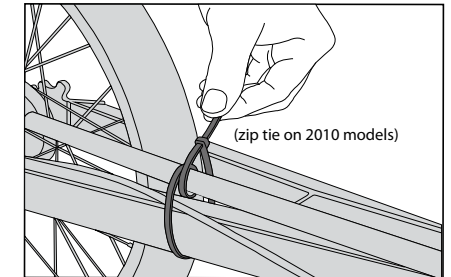

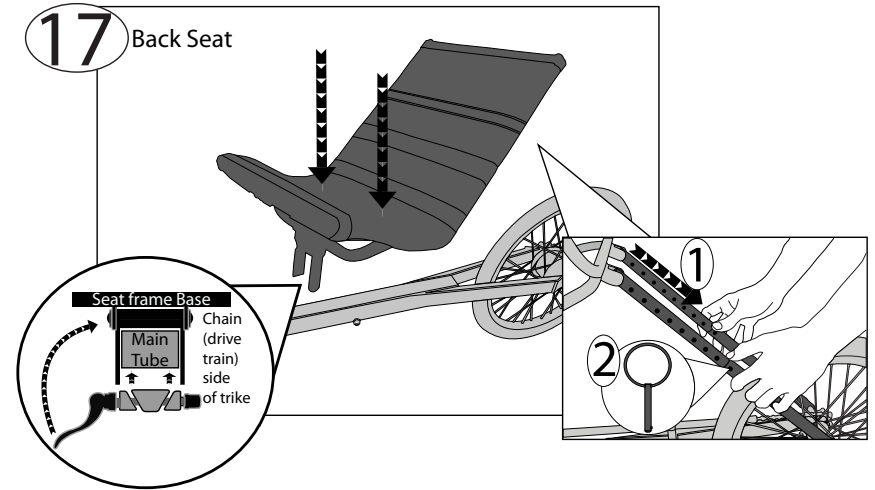
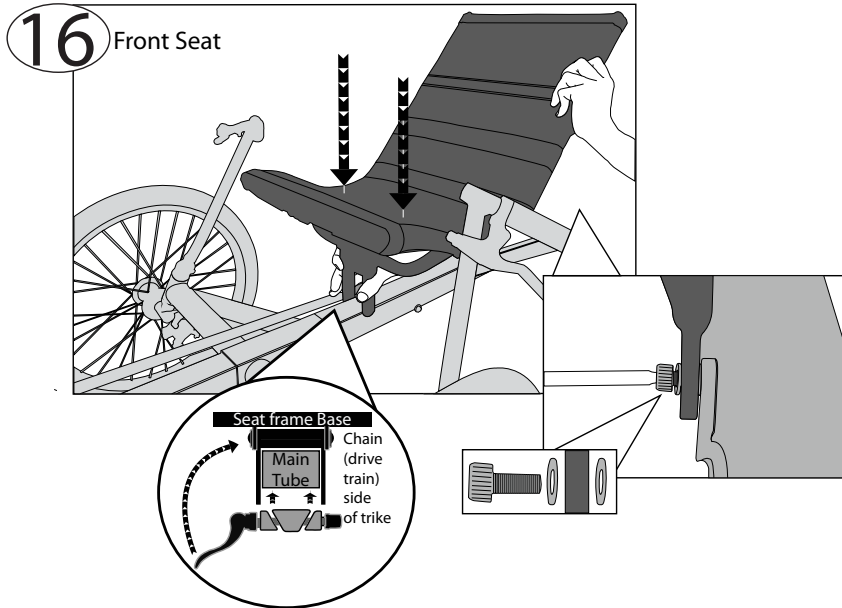
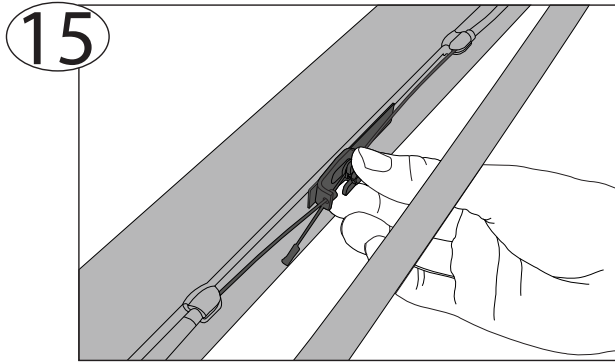

### Special Tandem Riding Considerations

Remember you are riding a tandem:

- It's not a sports car, so don't expect it to handle like one.
- You are moving twice the weight of a regular TerraTrike, and it will take longer to stop.
- Give yourself plenty of room to slow down.
- You also have a very long wheelbase. You will need to consider this when turning.
- Also, be considerate of, and communicate with your stoker (passenger).

## 2011 Rover X-seam Chart

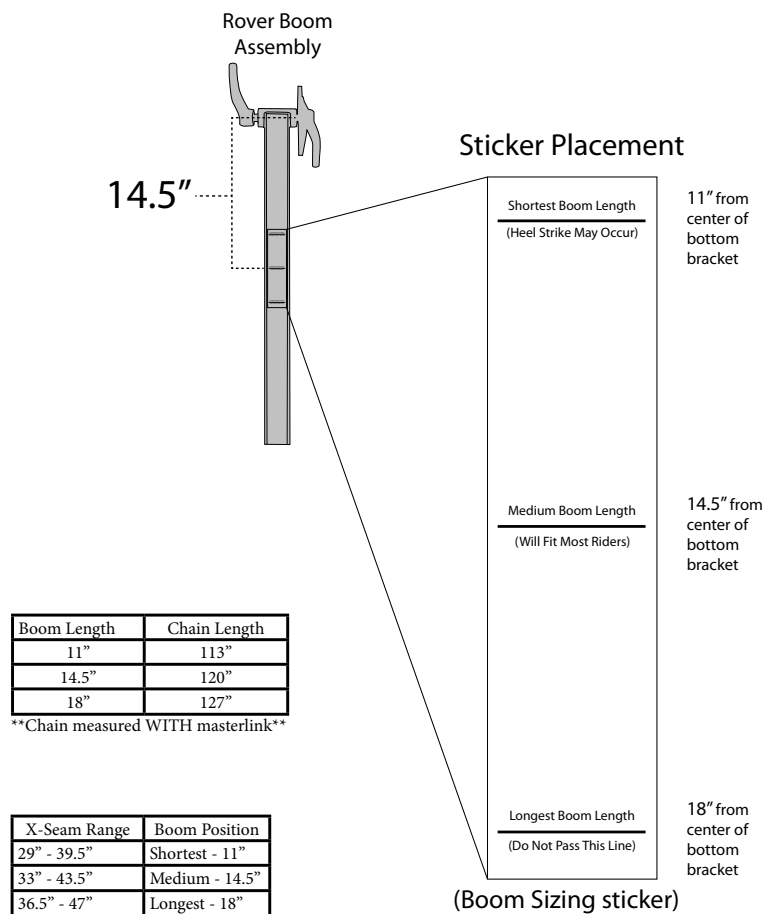

\*\*Boom positions are from center of bottom bracket to edge of front frame section\*\*

\*For X-seam measurement illustration, refer to X-seam measurement chart at: <http://www.terratrike.com/sizing.php>

Stoker (Passenger) X-seam Range: 31" - 42"  
Chain Length: 118"

SEE NEXT PAGE IF YOUR  
ROVER IS OLDER THAN 2011

## 2010 Rover X-seam Chart

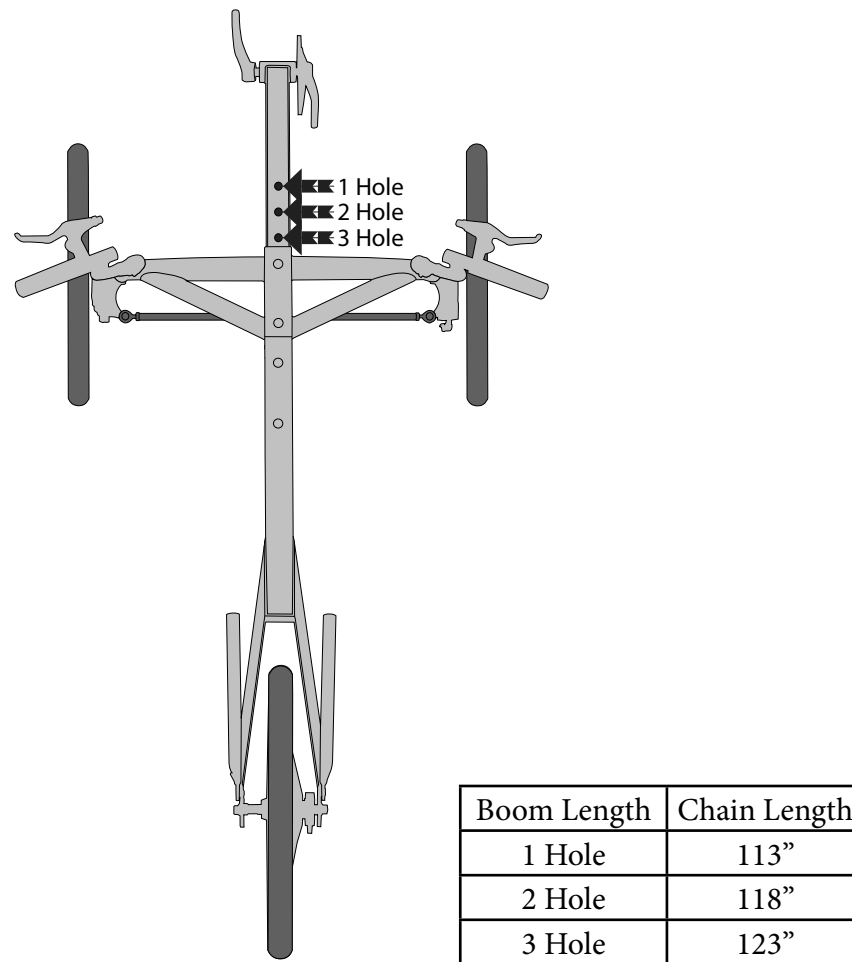

X-Seam Chart

Hole #	0	1	2	3
X-Seam Range	33.5" - 45"	36" - 47"	38" - 49.5"	40.5" - 51.5"

To determine the x-seam measurement, please refer to our catalog or <http://www.terratrike.com/sizing.php>

Stoker (Passenger) X-seam Range: 31" - 42"  
Chain Length: 118"

Welcome to our growing Family!

First Things First...Please read the information below BEFORE you go riding. It discusses everything from unpacking your trike to trike maintenance to riding tips. We want our customers to be safe and enjoy their trikes for years to come. Thank you for supporting our company, dealers and families by choosing TerraTrike.

### Unpacking

When your TerraTrike arrives, carefully unpack the contents and inspect for any damage that may have occurred during shipping. Notify your delivery person of ANY damage on the outside of the box. If anything is amiss, contact the TerraTrike Sales Office immediately at (616) 455-5988. Note: The tires may have little or no air in them. This is our normal shipping procedure to avoid damage from extreme altitude fluctuations.

**It's a good idea to flatten and save all boxes and packing materials. You may need them if you ever need warranty service or want to ship your TerraTrike.**

### Cautions/Safety

**Stop!** Make sure to read and understand this manual completely before riding your TerraTrike. We want to keep you riding safely for endless miles and years to come. So, always follow these safety precautions for each ride:

- Inspect your TerraTrike before each ride. Check the tires for proper pressure and any damage. Ensure that the brakes are functioning at their full capacity.
- Please remember a helmet is your most important piece of safety equipment. Wear one!
- If you ride at night make sure you have a white headlight visible from a distance of at least 500 feet, and a red rear taillight.
- Look behind you! We strongly recommend the use of a rear view mirror. Also make sure to turn your head and look before turning or changing lanes.
- Use caution when cornering. Learn to use safe speeds for negotiating corners and going down hills.
- Lean into turns when cornering at speed. Your TerraTrike can be "rolled" if turned too sharply for a given speed. Rule of thumb: rubber side down. :)
- The disc brakes and rotors will get very hot after braking. DO NOT touch them.
- Keep your feet securely on the pedals to prevent them from getting caught underneath your TerraTrike. We recommend clipless pedals or Power Grip pedal straps or heel straps.
- Brake evenly using both hands. Your TerraTrike is designed with front brakes only. You will experience brake-steer if you brake only one side.
- Although your TerraTrike is suitable for riding on dirt roads if equipped with more rugged tires, it is not designed for all-terrain, off-road use, or canyoneering. Loose sand can also be a headache.
- The unique look of your TerraTrike will attract much attention, so you're more likely to be seen.
- Be sure you are not obstructed from view by other vehicles. Use of a flag is highly recommended.
- Remember, your first line of defense is always your own common sense. Ride as if you are invisible to motorists and anticipate what they are going to do.
- Your TerraTrike is strong enough for most riding conditions. That is not a license to ride in a hazardous or abusive manner! Anyone can damage their TerraTrike if they try hard enough. Use common sense.
- Take care of yourself. We like our customers, and we want to keep them around.

### Riding Tips

Shifting: Simply twist the shifter up or down to find the desired gear. Sturmey Archer hubs should be shifted when you ARE NOT pedalling.

Riding Tips Cont.

- Turning:** When turning, you will find your TerraTrike does not lean into a corner the way a regular bicycle does. It behaves more like an automobile. For this reason you will feel a tendency to be pulled to the outside of a turn. To counteract this force, lean into the center of the turn. Please read the cautions and safety section carefully before taking high-speed turns.
- Stopping:** To stop, squeeze the brake levers. Each brake lever will activate the corresponding brake on each of the front hubs. To achieve a balanced braking effort, it is necessary to use both brake levers simultaneously. Brake evenly using both hands. You will experience brake steer if you brake only one side. Notice: New brakes will grip tightly and stop you abruptly.
- Parking:** To keep your TerraTrike from rolling away on inclines or in the wind, use the Velcro strap or locking brake levers included with your TerraTrike as a parking brake. Hold one of the brake handles down, wrap the strap around the handlebar and the brake lever, and secure it.
- Riding over small obstacles:** To successfully ride over obstacles, aim your TerraTrike so that the obstacle goes right under one of your feet. This way the rear wheel will not hit the object.

### Special Tandem Riding Considerations

**Remember you are riding a tandem. It's not a sports car, so don't expect it to handle like one. You are moving twice the weight of a regular TerraTrike, and it will take longer to stop. Give yourself plenty of room to slow down. You also have a very long wheelbase. You will need to consider this when turning. Also, be considerate of, and communicate with your stoker (passenger).**

### Survival Tips

- Keep your upper body quiet (no movement) while riding to avoid unwanted biofeedback, or tadpoling. This is especially crucial at speed.
- If you feel you are riding at high speeds regularly, you may want to consider a larger front chainring or Speed Drive option to slow down your cadence. To help avoid tadpoling, you'll want to ride with a slower cadence than you would on an upright bike.
- If you're taking your TerraTrike off-road, a knobby tire choice will give you more traction on dirt roads and other non-paved surfaces. The TerraTrike is not recommended on quicksand...or loose sand for that matter.
- Try to avoid being hidden by traffic while riding. A rear-view mirror and custom TerraTrike safety flag are highly recommended.
- Take water with you to re-hydrate your body. Your body perspires as you ride and you may not notice how much fluid you are losing due to the cooling affects of evaporation. Drink before you're thirsty.
- When riding your TerraTrike try to avoid extreme downhill mountain bike races, dare devil ramps, and near-earth orbit.
- Don't let your feet slip off the pedals. Your feet could get pulled under the outrigger tube resulting in an injury.

### Maintenance of Your TerraTrike

- Lubrication:** Chain and cables need regular lubrication with a good quality bike lube, available through TerraTrike or a local bike shop. All drive train parts will need periodic lubrication with the exception of the interanally geared hubs which are lubricated for life!
- Spokes:** Break-in period. During the first 100 miles, the spokes will experience a period of stretching to a degree more than that of a two-wheeled bicycle. This is due to the higher lateral (or side) forces applied to the wheels while turning. The spokes may require tightening, and the wheels truing. Have this performed by a qualified bicycle technician unless you have the necessary wheel truing skills.
- Brakes:** The brake cables will stretch in the early life of your TerraTrike. This is normal. To tighten the brake cables, turn the adjustment barrels. Replace the cables at the first indication of wear or fraying.
- Brake Balancing:** If the braking action ever appears to be uneven (one side brakes harder than the other), the brakes will need to be adjusted.
- Pads:** Unless you are routinely making transcontinental jaunts, the brake pads should last many seasons. If they do ever need replacing, contact your local bike shop.
- Shifters:** The shift cables will also stretch when new. You may need to adjust them occasionally as they break in.

•**Steering:** All of the steering parts tend to settle in after the first 100 miles or so. This may require some tightening of nuts and bolts.

•**Cleaning:** Your TerraTrike will operate for years to come if you keep it regularly cleaned and lubed! Water and soap won't hurt your TerraTrike, provided you dry and lubricate right after cleaning. If you need to wash the seat mesh, remove it from the seat frame, wash it in the gentle cycle and let it air dry. If you ride in inclement weather, immediately clean and lube your TerraTrike after your ride. **Road salt, over time, will cause significant damage to your TerraTrike. Clean it off immediately!** Likewise, salty air will corrode your TerraTrike. It's a good idea to wax the frame occasionally with a good quality car wax. We do use stainless steel nuts and bolts.

#### TerraTrike Lifetime Warranty

##### Lifetime Warranty

WizWheelz warrants to the original owner that all its trike frames, seat frames, and steering components are free of defective materials and workmanship subject to the limitations contained in this warranty. This warranty is limited to the lifetime of the original owner and is nontransferable. The Edge model carries a 3 year warranty. Warranty is conditioned upon the trike being purchased through and assembled by WizWheelz or an authorized WizWheelz dealer, operated under normal conditions, and maintained properly. Warranty does not apply to paint/finish or components attached to the frame. Attached components are subject to the warranty, if any, of their original manufacturer. Warranty claims must be presented to the place where the product was purchased whether that is an authorized WizWheelz dealer or the WizWheelz factory. Proof of purchase must accompany all requests for warranty coverage. WizWheelz reserves the sole discretion to repair or replace any parts covered by this warranty. Replacement parts may be a newer version than those originally purchased. Original owner shall be responsible for all labor, shipping, and travel costs related to repair or replacement of warranted parts. This warranty does not apply to normal wear and tear, or any defects, malfunctions, or failures that result from abuse, neglect, improper assembly, improper maintenance, overloading past specified load limit, alterations (i.e. cutting, spreading, drilling, welding, etc.), collisions, accidents, or misuse.

WizWheelz shall not be liable for any special, indirect consequential, incidental or other similar damages suffered by the purchaser or any third party, including, without limitation, damages for loss of profits or business or damages resulting from use or performance of the product, whether in contract or in tort, even if WizWheelz or its authorized representative has been advised of the possibility of such damages and WizWheelz shall not be liable for any expenses, claims, or suits arising out of or relating to any of the foregoing.

## Rover Tandem Owners Information

#### Disassembly

To break down your Rover Tandem, perform steps: 18, 17, 15, 12, 11, 10, 8, 6, 3, 2, 1 in the reverse action that's indicated. Ex. If the illustration indicates tightening a bolt, loosen it instead. Assembly videos are available online: <http://www.terratrike.com/manuals.php>

#### Shifting

Your Rover 8 will arrive with an internally geared hub in the rear wheel. In order to shift, STOP PEDALLING (coast), shift, begin pedalling again. The trike doesn't have to be stopped to shift into another gear. However, it's important that you DO NOT pedal when shifting. Pedalling while shifting can have a number of consequences. If the hub is damaged or malfunctions because of improper shifting technique, it WILL NOT be covered under warranty.

Also, internally geared trikes can be shifted to any gear at a stand-still. If you're in a high gear when you stop pedalling, shift into a lower gear to make acceleration easier.

#### Handlebar Adjustment

HANDLEBAR ADJUSTMENT VIDEO AVAILABLE ONLINE - <http://www.terratrike.com/manuals.php>  
Your Rover's handlebars are adjustable in two different ways:

- 1) The stiffness/ease of steering can be adjusted - you can make your Rover harder or easier to steer by adjusting your "Top Cap Bolts" (number 22 in the "Rover Manual" technical illustration).
- 2) They can rotate out and away from the rider - this gains a slightly wider riding clearance for wider people. This is also ideal for individuals with longer arms and/or broad shoulders.

If you decide to adjust your Rover's handlebars, follow the below steps:

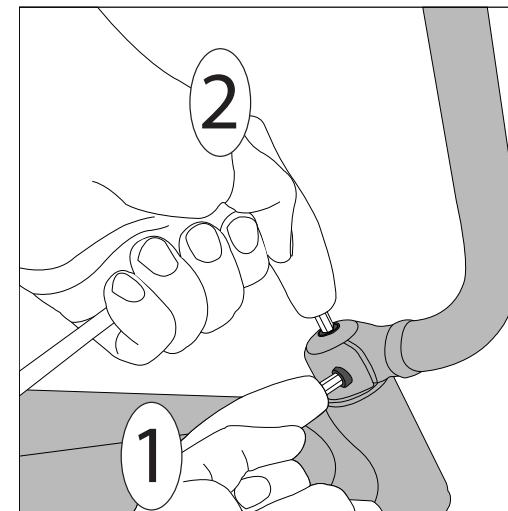

### Seating Position Adjustment

Your Rover seats are adjustable on two different planes: incline/recline angle of the seat back and fore/aft positions at the base.

Your Rover seating position has a significant amount of seating adjustment depending on where the “seat bracket” (number 9 on the technical illustration for the “Rover” manual) is located on the frame.

#### 1) Fore/Aft Seat Position-

To move the base of your seat, flip the quick-release lever down, slide the seat bracket along the main tube, flip quick-release lever to tighten the wedge setup. \*\*\*MAKE SURE THE WEDGES THAT REST AGAINST THE UNDERSIDE OF THE MAIN TUBE ARE POSITIONED CORRECTLY - IN THE ASSEMBLY MANUAL, STEP 7. ALSO, MAKE SURE THAT THE SEAT IS CLAMPED SECURELY\*\*\*

#### 2) Incline/Recline Position-

To adjust the incline/recline position (sitting up-right or laying back), pull the “seat stay pins” (number 29 in “Rover” technical illustration) from the “seat stays” (number 11 in the “Rover” technical illustration). You can now adjust your angle of recline (seat back angle). When you have a seating position you feel comfortable with, align the holes in the “seat stays” and reinstall your “seat stay pins” \*\*\*MAKE SURE THE HOLES IN THE SEAT STAYS LINE-UP WHEN YOU REINSTALL YOUR SEAT STAY PINS\*\*\*

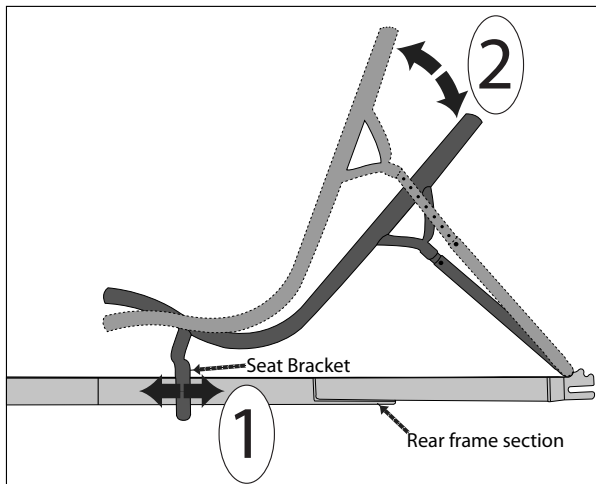

### Tire Pressure

Tire pressure is indicated on the side-wall of of each tire.

**\*\*TIRE PRESSURE SHOULD BE CHECKED BEFORE EACH RIDE.\*\***

The Rover uses “Schrader” valves. These valves are similar to car tires. A standard bicycle tire pump or air compressor will work to inflate these valves. **\*\*\*BE SURE NOT TO OVER INFLATE.\*\*\***

### NOTES

## COMPANY INFORMATION:

TerraTrike (WizWheelz Inc.)  
4525 Stauffer Ave SE, Suite A.  
Kentwood, MI 49508  
USA

### Email:

sales@terratrike.com - for Ordering & Customer Service  
tech@terratrike.com - for Technical Assistance  
shipping@terratrike.com - for Shipping Inquiries

### Phone:

1-800-945-9910 or 1-616-455-5988

### Fax:

1-616-455-6058

## RESOURCES:

- TerraTrike Forum - <http://www.terratrike.com/forum/>
  - TerraTrike Blog - <http://terratrike.com/blog/>
  - TerraTrike Facebook Page - <http://www.facebook.com/terratrike>
  - TerraTrike Twitter Page - <http://www.twitter.com/terratrike>
  - TerraTrike Youtube Channel - <http://www.youtube.com/wizwheelzterratrike>
  - TerraTrike Owners Group -<http://sports.groups.yahoo.com/group/wwog/>
  - Bentrider Online (BROL) - <http://www.bentrideronline.com/>
  - Recumbent Journal - <http://www.recumbentjournal.com/>
- \*Remember to subscribe!

## WARRANTY REGISTRATION:

**Register your trike online at: <http://www.terratrike.com/register.php>**  
**or**  
**Call us to register your trike - 1-800-945-9910**