

Tools Needed: 4mm and 5mm Allen Wrench, 10mm Open Ended Wrench

ITEM NO.	PART NUMBER	DESCRIPTION	QTY.
1	TT800028	REAR RACK	1
2	TT600084	RACK RISER	2
3	TT000992	STRAP, TAB REAR RACK	2
4	TT000859	STS Rack Clamp	2
5	WC000072	HW, M5 THUMB NUT	2
6	WC000159	HW, M6 THUMB NUT	4
7	TT000860	STS Rack Stay	2
8	WH000007	M6x1.0 Nylon Locknut SS	2
9	WH000001	M6x1.0 X 25mm SHCS SS	6
10	WH000056	M6x1.0 x 16MM SHCS STAINLESS STEEL	2
11	WH000005	M5x0.8MMx25MM SBHCS STAINLESS STEEL	2
12	TT600033	STRAP, RACK, DOUBLE HOOK, THREE PIECE (BY-601N)	1
13	WH000055	M6 Flat Washer w/12mm OD, SS	2

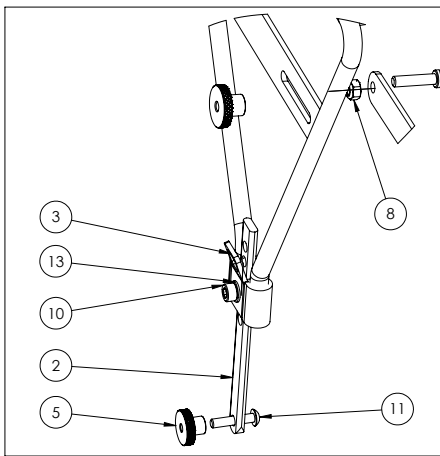
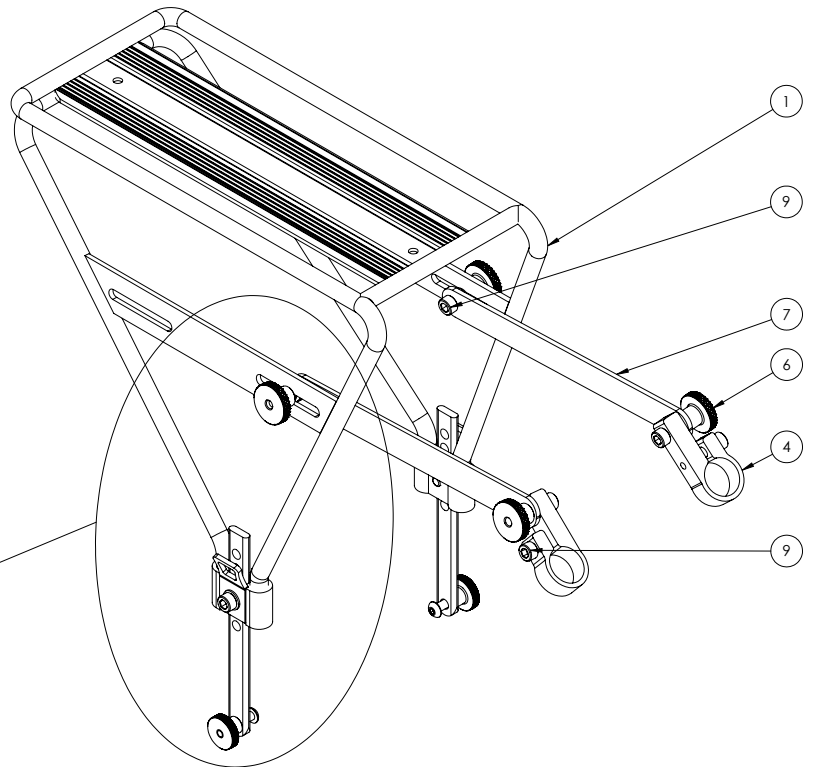

Assembly Instructions:

Prior to assembly, remove rear wheel and separate upper seat stays from lower seat stays. Remove quick release clamps. *Note: For installation on Spyder or ATC models, Rear Rack Fit Kit (TT600906) is required.

- 1** Attach Rack Stays (7) to Rear Rack (1):
 Insert M6x25 bolt (9) through Rack Stay mounting hole. Thread M6 Nylon Nut (8) onto bolt, and fasten tight. Insert bolt through slot on Rear Rack. Install M6 Thumb Nut (6) and leave finger tight. Refer to exploded view for proper fastener orientation.
- 2** Attach Rack Risers (2) to trike frame:
 With the rear wheel removed, install M5x25 bolts (11) into frame threads on inside of dropouts. Attach Rack Risers to bolts and fasten tight using the M5 Thumb Nuts (5).
- 3** Attach Rack to Rack Risers:
 Install Rear Rack (1) onto Rack Risers (2) using the M16x16 bolts (10), M6 Flat Washers (13), and Strap Tabs (3). Refer to the exploded view for proper orientation.
- 4** Install Rack Clamps (4) onto Seat Stays:
 With the upper and lower seat stays separated from one another, and quick release clamps removed, slide the Rack Clamps (4) onto lower seat stays with the hardware facing outward. Leave mounting bolts loose. Reinstall quick release clamps on lower seat stays and reconnect seat stays.
- 5** Attach Rack Stays (7) to Rack Clamps (4):
 Attach Rack Stays (7) to Rack Clamps (4) on seat stays using the M6 Thumb Nuts (6). Leave

- 6 Level the Rack and tighten all fasteners.

Complete assembly:

