

Tools Needed: 5mm allen wrench, 8mm allen wrench, 13mm wrench.

Assembly Instructions:

- 1 Attach idler wheel (4) to chain tensioner plate (1) using the M8x40 bolt (7), 20mm spacer (5), and M8 nyloc nut (6). Install chain tensioner assembly onto frame using the M10x20 bolt (2) and M10 lock washer (3), leave bolt loose enough to allow adjustment of the mounting plate. Route chain over top of idler wheel and adjust position of mounting plate until chain is taut. Tighten M10x20 (2) bolt.

ITEM NO.	PART NUMBER	DESCRIPTION	QTY.
1	TT000856	CHAIN TENSIONER, TANDEM PRO	1
2	WH000010	M10x20mm SHSC, SS	1
3	WH000011	M10 Lock Washer	1
4	TT000261	IDLER, 10T DELUXE	1
5	TT000123	Spacer, 20mm L, 8mm ID x 10mm OD	1
6	TT000287	TIE ROD/IDLER/SEAT/BOOM NUT	1
7	TT000278	M8x40 Button head socket cap screw, SS	1

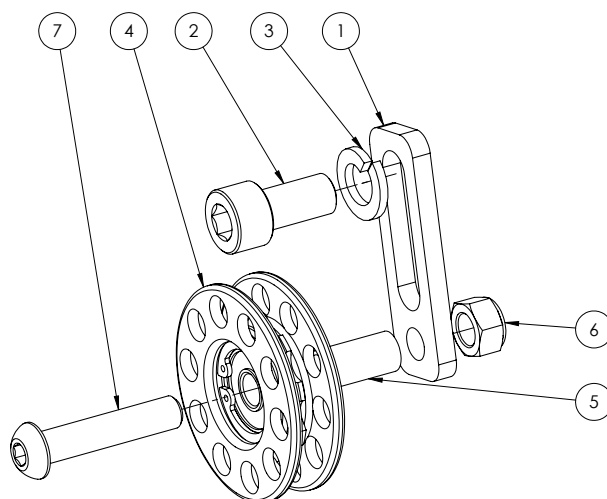
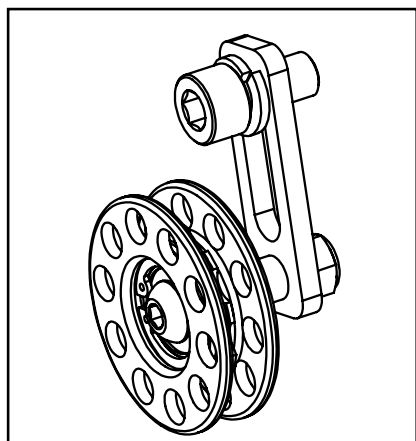

TerraTrike.com | 800.945.9910

Tools Needed: 5mm allen wrench, 8mm allen wrench, 13mm wrench.

Assembly Instructions:

- 1 Attach idler wheel (4) to chain tensioner plate (1) using the M8x40 bolt (7), 20mm spacer (5), and M8 nyloc nut (6). Install chain tensioner assembly onto frame using the M10x20 bolt (2) and M10 lock washer (3), leave bolt loose enough to allow adjustment of the mounting plate. Route chain over top of idler wheel and adjust position of mounting plate until chain is taut. Tighten M10x20 (2) bolt.

ITEM NO.	PART NUMBER	DESCRIPTION	QTY.
1	TT000856	CHAIN TENSIONER, TANDEM PRO	1
2	WH000010	M10x20mm SHSC, SS	1
3	WH000011	M10 Lock Washer	1
4	TT000261	IDLER, 10T DELUXE	1
5	TT000123	Spacer, 20mm L, 8mm ID x 10mm OD	1
6	TT000287	TIE ROD/IDLER/SEAT/BOOM NUT	1
7	TT000278	M8x40 Button head socket cap screw, SS	1

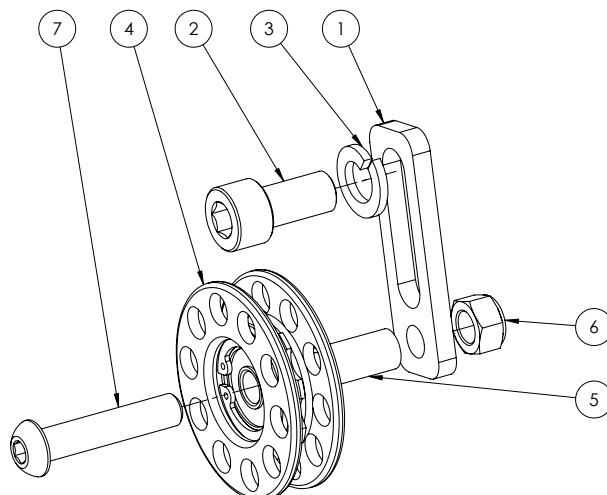
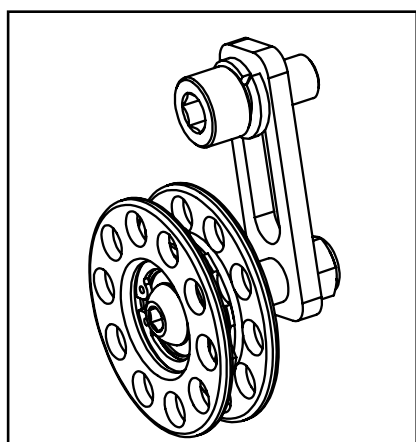

TerraTrike.com | 800.945.9910